

Example connection of the EFS signal output: driving an audible alarm device.

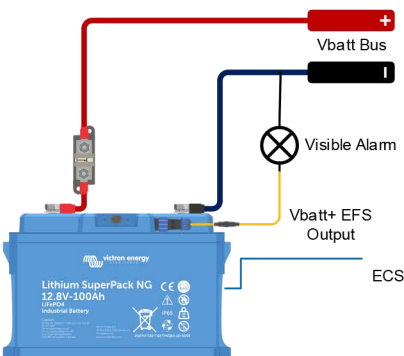

Example (12,8V model) connection of the EFS signal output: driving a visible alarm device. Bus voltage is model-dependent.

The Lithium SuperPack NG battery is a drop-in replacement for standard lead-acid batteries in RVs and recreational vehicles. Designed for extended off-grid use, it provides ample capacity to power the complete electrical system, including high-demand appliances. Its form factor and terminal layout ensure easy installation in a wide range of vehicles such as large trucks, SUVs, and RVs.

Features

- **Bluetooth monitoring and control** Includes Bluetooth Smart for wireless configuration, monitoring, and firmware updates via the [VictronConnect App](#). The Instant Readout function displays key data such as state of charge (SoC), battery temperature, warnings, and alarms directly in the device list without the need to connect.
- **Built-in BMS and battery monitor:** Integrates cell balancing, protection, and monitoring functions to ensure optimal performance and safety throughout the battery's service life.
- **External Feedback Signal (EFS):** Provides a battery voltage signal limited to 250 mA. The EFS signal serves as an External Disconnection Signal (EDS) to trigger an event for redundant system protection. Additionally, the EFS can be configured as an External Charging Signal (ECS), based on the low SoC pre-alarm threshold, to activate a charger start signal.
- **Self-heating function:** Maintains the battery temperature above the minimum safe charging limit to ensure reliable operation in cold environments. Two heating modes are available:
 - **Charger mode:** the heater is powered by the connected charger and activates automatically when the cell temperature drops below 0 °C before charging (default).
 - **Auto mode:** The battery powers the heater to keep the cells above the minimum safe charging temperature for immediate charging. This is limited by the battery's internal energy; if SoC falls below the Low SoC threshold, the heater is disconnected and charging remains unavailable.
- **LED status indication:** Two integrated LEDs indicate Bluetooth connectivity, warning and alarm conditions, or firmware update status.
- **On/Off push button:** Push button for switching the battery on or off, disabling both charging and discharging functions to allow safe operation and extended storage time.
- **High efficiency:** Operating efficiency 93 %.
- **Parallel connection:** Supports parallel connection of an unlimited number of batteries to increase total energy capacity. The total system current should not exceed the maximum current that a single battery can safely interrupt.
- **Configurable discharge floor:** Defines a minimum state of charge to avoid excessive discharge while keeping reserve capacity. When the limit is reached, VictronConnect shows a Low SoC alarm and the Allowed to Discharge (ATD) indicator turns off until the state of charge rises above the set threshold.



Lithium SuperPack 12,8/100 NG



Lithium SuperPack 12,8/200 NG & 25,6/100 NG



Lithium SuperPack 25,6/200 NG & 51,2/100 NG



Live battery data displayed in VictronConnect

Lithium SuperPack NG	12,8V/100Ah	12,8V/200Ah	25,6V/100Ah	25,6V/200Ah	51,2V/100Ah
Part Number	BAT512110740	BAT512120740	BAT524110740	BAT524120740 ¹⁾	BAT548110740 ¹⁾
Nominal voltage	12,8 V		25,6 V		51,2 V
Nominal capacity @ 25 °C ²⁾	100 Ah	200 Ah	100 Ah	200 Ah	100 Ah
Nominal energy @ 25°C ²⁾	1280 Wh	2560 Wh		5120 Wh	
Capacity loss / Energy loss	(per 100 cycles, @25 °C, 100 % DoD): <1%				
Round Trip Efficiency ³⁾	93 %				
CYCLE LIFE 25 °C (capacity ≥ 80% of nominal)³⁾					
Cycle life	2500 cycles @80 % DoD 3000 cycles @70 % DoD 5000 cycles @50 % DoD				
DISCHARGING					
Recommended discharge current (continuous use)	50 A	100 A	50 A	100 A	50 A
Max continuous discharge current ⁸⁾	200 A	400 A	200 A	400 A	200 A
End of discharge voltage	11,2 V		22,4 V		44,8 V
Internal resistance	2 mΩ	1 mΩ	4 mΩ	2 mΩ	8 mΩ
CHARGING					
Recommended charging voltage	14 V		28 V		56 V
Float voltage	13,5 V		27 V		54 V
Charging voltage range	[13,5 - 14,2] V		[27 - 28,4] V		[54V - 56,8] V
Recommended charging current	30 A	60 A	30 A	60 A	30 A
Max continuous charging current ⁸⁾	100 A	200 A	100 A	200 A	100 A
FEATURES					
Hardware protection / System Max Current	Short circuit above 800 A				
Software protections	Overvoltage, Undervoltage, Overtemperature, Undertemperature, Overcurrent				
Wired Communication	External Feedback Signal (EFS)				
Bluetooth	Yes, VictronConnect App				
User Interface	Push button (On/Off), BLE LED, Error LED				
Self-heating max power	65 W	130 W		260 W	
OPERATING CONDITIONS					
Parallel configuration	Yes, unlimited energy expansion, with power expansion limited to the system's maximum current				
Series configuration	No				
Operating temperature	Charge ⁷⁾ and discharge: -30 °C to +60 °C				
Humidity Operating Range (non condensing)	<90 % RH				
Storage temperature	Recommended [10 - 35] °C Expanded [-40 to +65] °C ⁴⁾				
Max storage time @ 25°C	1 year with at least initial remaining SoC>50 %				
Protection class	IP65				
MOUNTING					
Power connection (threaded insert)	M8 female 20 mm including nut screws				
Mounting options	Upright and on its long side, maintain flat horizontal support				
Dimensions [LxWxH] (mm) ⁵⁾	273 x 173 x 173 ⁶⁾	466 x 198 x 173		871 x 198 x 173	
Weight (kg)	10,7	20,5		41	
STANDARDS					
Safety	Cells: IEC62619 UL1973 UL 9540A Battery: IEC62619 (pending)				
EMC	EN 61000-6-3, EN 61000-6-2				
Performance	IEC62620 (pending)				
Transportation	UN38.3				
Automotive	ECE R10-7			ECE R10 (pending)	
Notes	¹⁾ Product launch after Q1 2026 ²⁾ Discharge current ≤1C ³⁾ 25 °C and 0.5C cycling ⁴⁾ Performances might be reduced ⁵⁾ Additional height of 15 mm for terminal screws		⁶⁾ Compatible with BCI Group 49 dimensions ⁷⁾ Below 0 °C, charging is suspended while the internal self-heating function warms the cells and automatically resumes once a safe charging temperature is reached. ⁸⁾ Above this limit, protection is triggered within 10 seconds.		